

# SAFEPACE® 450

Radar Sign



TRAFFIC SAFETY  
SUPPLY COMPANY

## PRODUCT DESCRIPTION

The compact SafePace® 450 sign offers lightweight entry-level speed display for private communities or local roads. The economical sign offers remarkable power efficiency and quick, easy installation.

## DIMENSIONS

- » Digits: 15.0"(h) x 8.0"(w), 112 LEDs per digit
- » Text:
  - Full Size: Letters 6.0"(h) spell "YOUR SPEED" fixed message, 2 lines
  - Compact Size: Letters 4.0" (h) spell "YOUR SPEED" fixed message, 1 line
- » Unit alone: 21.5"(h) x 26.0"(w) x 3.5"(d)
- » Unit with "YOUR SPEED" sign mounted:
  - Full Size: 40.0"(h) x 30.0"(w) x 3.5"(d)
  - Compact Size: 28.0"(h) x 26.0"(w) x 3.5"(d)
- » Sign Weight (unit alone without "YOUR SPEED" sign)
  - AC Powered Model: 18 lbs
  - 4 Cell Battery Powered Model: 22 lbs
  - Solar Powered Model: 20 lbs (does not include solar panel or solar panel bracket)
- » Accessories
  - 4 Cell Lithium Ion Battery: 4 lbs
  - Universal Mounting Bracket System
    - Sign Bracket: 2 lbs
    - Pole Bracket: 5 lbs

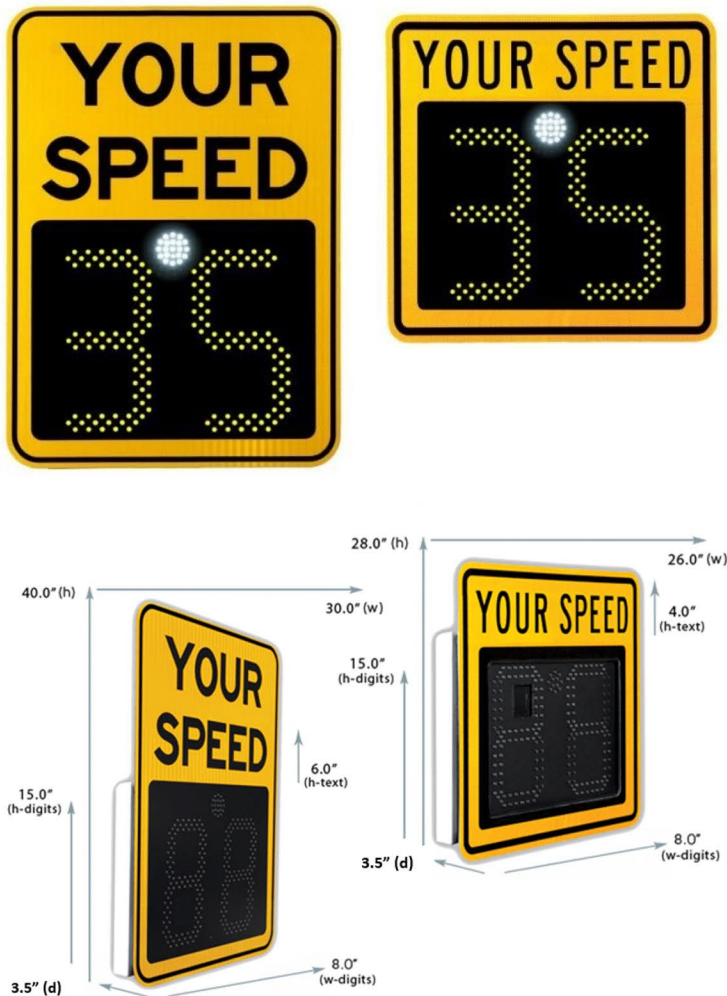

**Note: Specifications are approximate and subject to change. Some parts shown may be for illustration purposes only.**

# SAFEPACE® 450

## Radar Sign



TRAFFIC SAFETY  
SUPPLY COMPANY

## TECHNICAL SPECIFICATIONS

- » Miles Per Hour (mph) or Kilometers Per Hour (km/h)
- » Aluminum protective cover: 0.1875" (d)
- » Yellow or white high-Intensity prismatic reflective sheeting on the sign face with black colored text
- » MUTCD approved colors and format
- » Operating Temperatures F (C): -40° (-40°) to 185° (85°)
- » Conformal coating on all circuit boards

## Power

- » Power input:
  - 100~240 V AC
  - 12VDC
  - Built in ambient light sensing and automatic brightness control
  - Wireless battery charge monitor
- » Power Options
  - AC power input: 100~240 V AC
  - DC power input: 12 V DC
  - Solar power: 50W, 90W solar panel

## Radar

- » Internal Radar: Doppler (FCC approved)
- » Radar RF out: 5 mW maximum
- » Radar f-center: 24.125 GHz center +/- 25 MHz
- » Pickup distance: Up to 1,200 feet
- » Beam angle: 24° (vertical) x 12° (horizontal)
- » Beam polarization: Linear

## Display

- » LEDs 245:
  - Digits: 224 Amber, 23°, 5 mm, luminous Intensity (5,000 – 12,000 mcd/LED)
  - Speed Violator Strobe: 21 White, 15°, 5 mm, luminous intensity (18,000 – 28,000 mcd/LED)
- » Optical lenses: 245 lenses
- » Ambient light sensor and automatic brightness adjustment

## Enclosure

- » 12 gauge aluminum, flat black powder coated front for reduced glare and maximum contrast; light gray powder coated body to minimize heat absorption
- » Weatherproof, NEMA 4X-12, IP65 level compliant
- » Non-sealed and ventilated

## Mounting Options

- » Banding brackets (standard)
- » Universal Mounting Bracket System
  - Universal mounting options: circular, square and telspar poles
  - Theft resistant
  - Promotes sign portability: sign locks into mounting bracket with a turn of a key

**Note: Specifications are approximate and subject to change. Some parts shown may be for illustration purposes only.**

# SAFEPACE® 450

Radar Sign



TRAFFIC SAFETY  
SUPPLY COMPANY

## COMMUNICATIONS



- » Bluetooth (standard)
- » GSM/GPRS (optional, for use with SafePace Cloud)

## PROGRAMMING

- » SafePace® Pro management software
- » SafePace® Cloud remote management
- » 24/7 365 day unlimited programming and scheduling
- » Display Settings:
  - Display On/Stealth Modes (In Stealth Mode, speed is not displayed but data is collected)
  - Display Minimum Speed, Display Maximum Speed
  - Digit Flashing Speed Threshold (digits flash above specified speed threshold)
  - LEDs Flashing Speed (for digits)
    - Fast: 1.5 Hz
    - Medium: 1 Hz
    - Slow: 0.75 Hz
  - Speed Violator Strobe (pulsing strobe flashes with digits or alone above Display Maximum Speed)

**Note: Specifications are approximate and subject to change. Some parts shown may be for illustration purposes only.**

## DATA COLLECTION STATISTICAL ANALYSIS AND REPORTING (OPTIONAL FEATURE)

- » Traffic data collected and stored by location
- » Stealth Mode (captures baseline traffic data with speed display turned off)
- » Download through wireless connection
- » Statistical Reporting & Charts
  - Summary Reports
  - Weekly Reports
  - Period Comparison Reports
  - Full custom reports and charts
  - Reporting Parameters:
    - Average Vehicle Count
    - Total Vehicle Count
    - Average Speed
    - Average Number of Speed Violations
    - Total Number of Speed Violations
  - Other Features:
    - Minimum and Maximum Speed
    - 85% Speed
    - Counters by Speed Bins
    - 5 MPH Bin Resolution
    - Reports print directly or can be exported into CSV format, MS Excel, Adobe Acrobat PDF and HTML
    - Charts may be printed directly or converted into Adobe Acrobat PDF and image formats



### Two Year Warranty

Two year warranty on parts and labor  
excluding damage related to  
vandalism, abuse, and/or theft

# SAFEPACE® 450

Radar Sign



TRAFFIC SAFETY  
SUPPLY COMPANY

## UNIVERSAL MOUNTING BRACKET SYSTEM

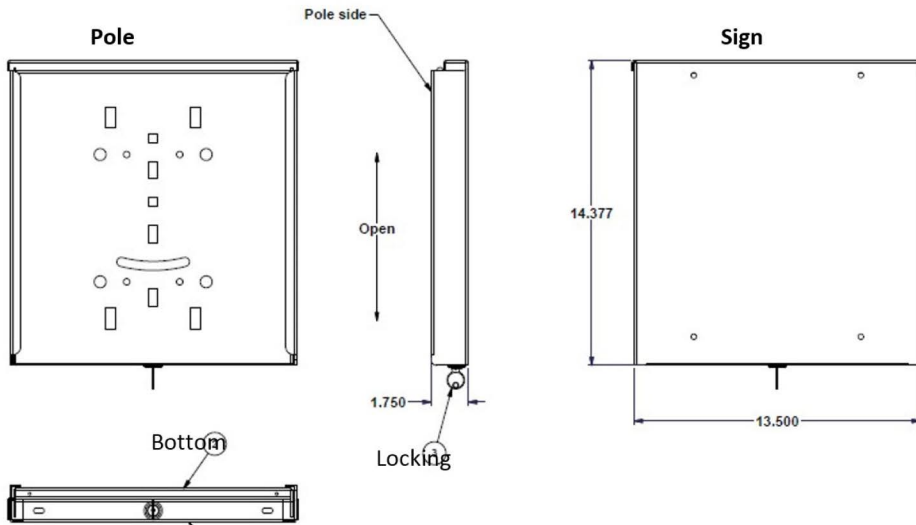

## Inside View

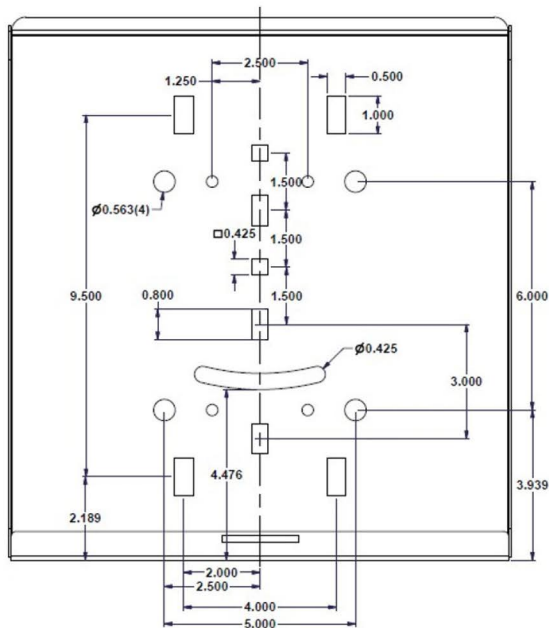

Note: Specifications are approximate and subject to change.  
Some parts shown may be for illustration purposes only.