

# CrashGard® Temporary Attenuator

Attenuator



TRAFFIC SAFETY  
SUPPLY COMPANY

## PRODUCT DESCRIPTION

CrashGard Sand Barrel System is a non-redirective, gating sand barrel, or crash cushion. Sand barrels are designed to protect fixed objects, whether permanent or temporary. Sand barrels are designed to reduce the likelihood of a vehicle impacting the object.

## FUNCTION OF A SAND BARREL

As the AASHTO\* Roadside Design Guide states, sand barrels absorb energy. AASHTO also states:

- » Sand barrels stop the impact vehicle in a short distance and at a controlled rate.
- » The controlled rate reduces the potential for injury to the occupants.
- » Sand barrels allow the vehicle to pass through the array but they do not redirect the vehicle.

\*Association of American State Highway and Transportation Officials

**Note: Specifications are approximate and subject to change. Some parts shown may be for illustration purposes only.**



# CrashGard® Temporary Attenuator

## Attenuator



**TRAFFIC SAFETY  
SUPPLY COMPANY**

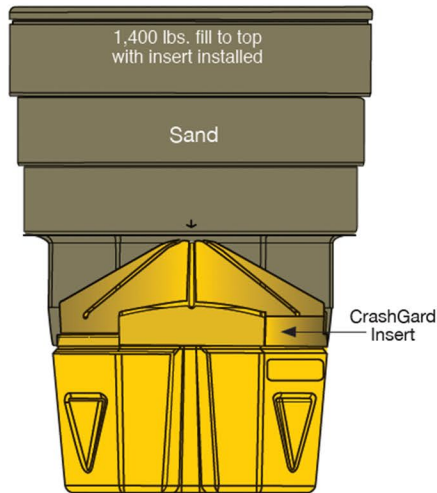

### To meet MASH Requirements

#### Fill to Top - With Insert

We will ship barrels with the "1,400 lbs. fill to top mark" beginning April, 2019.



### To meet NCHRP-350 Requirements

#### Fill to Line - No Insert

We will ship barrels with this "1,400 lbs. fill mark" through March, 2019.

## FHWA LETTERS

- » In March, 2007, FHWA issued PSS Acceptance Letter CC-97 for CrashGard Sand Barrel System. CC-97 acknowledges that CrashGard passed NCHRP-350 Crash Tests 3-40 through 3-44. The letter also confirms that CrashGard meets the criteria of NCHRP-350 Test Level 3 for non-redirective, gating crash cushions.
- » In March, 2009, FHWA issued CC-97A, an amendment to the original letter. The amendment accepts the use of CrashGard in "mixed array" configurations. Please see page 10 for correct placement of CrashGard in mixed arrays.
- » AASHTO\* MASH\*\* test requirements supersede NCHRP-350 test requirements. Crash cushions are required to comply with MASH test guidelines by December 31, 2018.
- » PSS tested CrashGard to MASH Test Level 3 in Spring, 2018. FHWA issued Eligibility Letter CC-145 for CrashGard in September, 2018.
- » In CC-145, FHWA agrees that CrashGard meets MASH test and evaluation requirements. CC-145 also states that FHWA finds CrashGard eligible "for reimbursement under the Federal-aid highway program." For a copy of CC-145, please visit [pss-innovations.com](http://pss-innovations.com) or <http://bit.ly/2Q9NjRz>. See Page 9 for a summary of CrashGard MASH tests.
- » Use of Existing CrashGard Inventory: PSS did not change the design or function of CrashGard to meet MASH requirements.
- » Users can confidently install any CrashGard Sand Barrel System purchased prior to the issuance of CC-145 and still meet MASH requirements.
- » However, users must comply with one change we made to the sand-fill procedures. Under NCHRP-350 requirements, our 1,400 lb. barrel did not require use of CrashGard Insert. Users simply filled barrels to the 1,400 lb. fill mark.
- » To meet MASH requirements, users must now install CrashGard Inserts in 1,400 lb. barrels, and then fill with sand to the "1,400 lbs. fill to top mark".
- » Barrels shipped until the end of March, 2019 will show the "1,400 lbs. fill mark", as per the example, below left.
- » Beginning April, 2019, barrels shipped will show the "1,400 lbs. fill to top mark", as per the example, below right.

\*Association of American State Highway and Transportation Officials

\*\*Manual for Assessing Safety Hardware



MASH Test Level 3-45, Spring 2018

**Note: Specifications are approximate and subject to change. Some parts shown may be for illustration purposes only.**

# CrashGard® Temporary Attenuator

## Attenuator



**TRAFFIC SAFETY  
SUPPLY COMPANY**

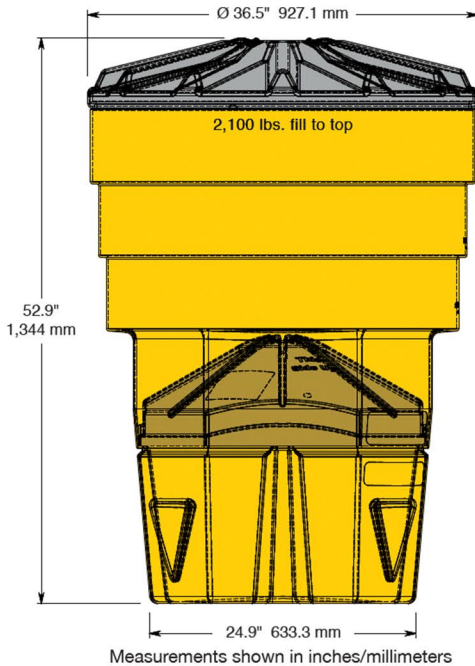

## SYSTEM DESCRIPTION

CrashGard Sand Barrel System consists of 3 components: Barrel, lid, and insert

### Barrel, P/N CC-48:

- » Dimensions: 36.0" diameter, 48.0" height.
- Configuration of lower portion: configured in a square profile, which creates lifting shelves at the intermediate section of the barrel.
- Design function of lifting shelves: provide support for forklift transport.
- » Configuration of upper portion: configured in a straight wall. Groove in top of barrel allows for snap-on lid. Barrels will easily nest when empty of contents and with insert and lid removed.
- » Design function of straight wall: allows for easy application of retro-reflective sheeting, and supports the CrashGard Hoist lift ring used for transport.
- » Maximum ballast: 2,100 lbs. of sand.
- The barrel is marked externally with the following fill marks: 200, 400, 700, 1,400 and 2,100 lbs.
- » Molding process and material: blow-molded from high molecular, high density polyethylene (HLMI-HDPE) material, which includes UV stabilizer agents. Safety Yellow in color.

### Insert, P/N CC-128:

- » Dimensions: 27.0" square, 10.8" height.
- » Configuration: conical in shape. Inserts will nest.
- » Design function: allows for ballast of either 200, 400, 700 or 1,400 lbs. of sand when installed on the ledge molded into the internal lower portion of the barrel. Install conical side up, as indicated.
- » Molding process and material: rotationally molded from high density polyethylene (HDPE) material.

### Lid, P/N CC-L36:

- » Dimensions: 36.5" diameter, 6.6" height.
- » Configuration: round in shape. Lids will nest.
- » Design function: tamper-resistant fit on top of barrel. Reduces vandalism and infiltration of water. Lip of lid snaps into a groove in the top of the barrel.
- » Molding process and material: blow-molded from high molecular, high density polyethylene (HLMI-HDPE) material, which includes UV stabilizer agents. Black in color.

PSS designed CrashGard Sand Barrel System for the intended use as a gating, non-reflective crash attenuator

**Note: Specifications are approximate and subject to change. Some parts shown may be for illustration purposes only.**

# CrashGard® Temporary Attenuator

## Attenuator



**TRAFFIC SAFETY  
SUPPLY COMPANY**

### Weights and Dimensions

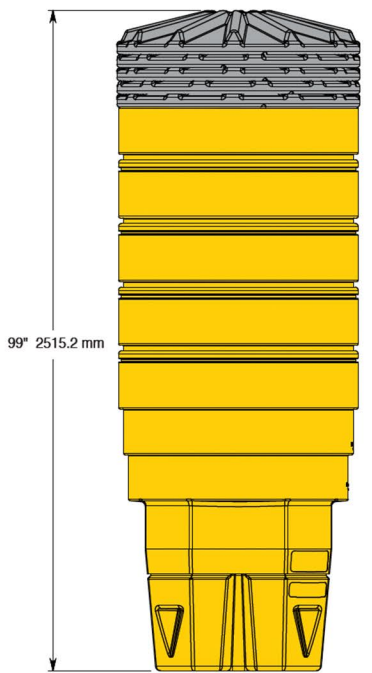
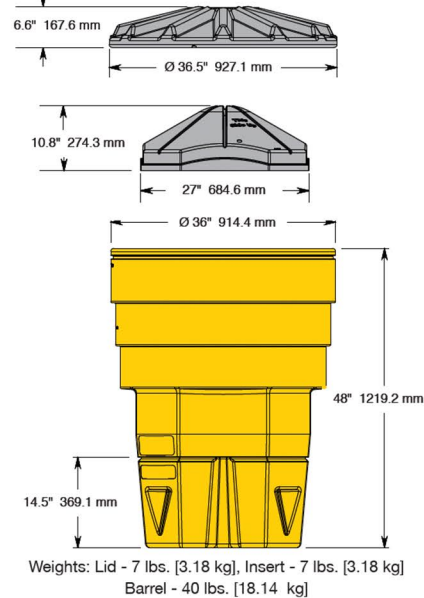

DOT Approved installations »

### DESIGN AND PLACEMENT OF ARRAYS

- » Design and placement of arrays will adhere to guidelines established in:
  - AASHTO Roadside Design Guide
  - FHWA Report N5040.16, Crash Cushions, Selection Criteria and Design
- » Properly designed arrays (as described on page 8) will decelerate the vehicle within the parameters described in MASH Certification.
- » PSS has tested the CrashGard Sand Barrel System to the requirements set forth in MASH Certification, Test Level 3. See page 2 for more information.

### CRASHGARD SAND BARREL SYSTEM LIMITATIONS

- » CrashGard Sand Barrel System meets MASH criteria, test Level 3, for non-redirective, gating crash cushions. It should not be used for any other function.
- » Impacts that exceed design capabilities may not result in acceptable crash performances as described in MASH criteria, Test Level 3.



### SHIPPING CONFIGURATIONS

- » A truckload stack consists of 5 CrashGard Barrels and 5 lids, both nested.
- » The amount of CrashGard barrels per truckload depends upon the amount of inserts required. Call us with your array requirements, and we will calculate shipping configurations for you.

### CRASHGARD SAND BARREL SYSTEM WARRANTY

- » PSS warrants each CrashGard Sand Barrel System is free from manufacturing defects for one (1) year from date of purchase. (Subject to additional terms and conditions. Please contact PSS for complete warranty.)
- » PSS warrants each CrashGard Sand Barrel System against UV degradation for six (6) years from date of purchase, on a pro-rated, "repair or replace" basis.



**Note: Specifications are approximate and subject to change. Some parts shown may be for illustration purposes only.**

# CrashGard® Temporary Attenuator

## Attenuator



TRAFFIC SAFETY  
SUPPLY COMPANY

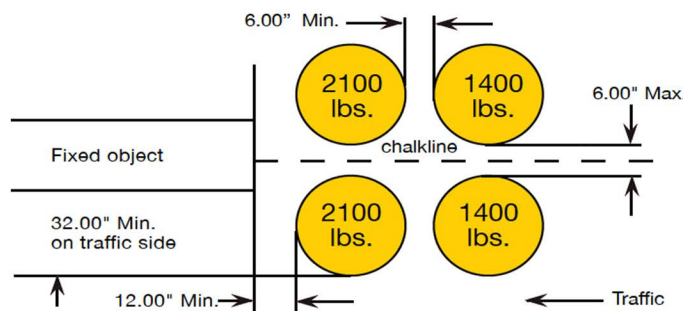

### INSTALLATION PROCEDURE

- » Installers should adhere to state specifications or drawings.
- » Review all engineering plans prior to installation for proper design array. Contact TSSCO for questions about CrashGard Sand Barrel System.
- » TSSCO recommends the following installation procedure, with dimensions as noted. Note well that state specifications may differ from our recommended dimensions. State specifications always supersede our recommendations.
- » For example, we recommend a minimum 12" space between the fixed object and the first row of barrels. However, some states specify a minimum of 18". In that case, installers should follow the state specification, and place the barrels at least 18" from the fixed object.

### PREPARE THE SITE

- » Implement proper traffic control procedures to protect workers and the driving public.
- » Clear the site of any debris or snow.
- » Measure the grade of the installation site.
- » The grade should not exceed 5% in either direction. The site requires grading, if over 5%.

**Note: Specifications are approximate and subject to change. Some parts shown may be for illustration purposes only.**

### SET THE FIRST ROW

- » The row of sand barrels, closest to the fixed object, and perpendicular to traffic, is considered the first row. Start the installation at the first row, as the rows should follow a straight line.
  - Laterally offset the first row, on the side of traffic, a minimum of 32".
  - Allow for a minimum 12" of space between the first row and the fixed object.

### SET THE REST OF THE ARRAY

- » Mark the centerline of the array with a chalk line or other marking device. (This works especially well for new installations.)
- » Adhering to the centerline, set each barrel in place:
  - Allow a minimum of 6" between barrels parallel to traffic. Measure from the top of the barrel.
  - Allow a maximum of 6" between barrels perpendicular to traffic. Measure from the top of the barrel.

**Caution: If the sand has been heated recently, make sure it is cool before filling any barrels. Hot sand could distort the barrel, or insert, and cause leaks.**

### FILL THE BARRELS

- » To meet MASH requirements, please see new sand-fill measurements for 1,400 lb. barrels on page 2.
  - Filling the barrels offsite: follow the directions below, but also make sure to mark the barrels with their respective weights, to avoid misplacement in the array.
- » Filling the barrels on site:
  - Review the array plans or drawings to determine the appropriate weight for each barrel.
  - Install CrashGard Insert for weights of 200, 400, 700 and 1,400 lbs.
  - Weights of 2,100 lbs. do not require Inserts.
- » Compact the sand to achieve proper fill.
- » Fill the barrels with the appropriate weight of sand, using the fill level marks on the side of the barrel.
- » Use only sand that meets ASTM C-33, washed concrete sand or equivalent. Use only sand that contains less than 3% moisture. In freezing conditions, add a minimum of 5% rock salt. In all cases, sand must meet state specifications.
- » Press a lid on each barrel. Check that each has completely snapped into the lid groove on the barrel. Compare the array to the specifications for a final check. Clean-up area.

# CrashGard® Temporary Attenuator

## Attenuator



**TRAFFIC SAFETY  
SUPPLY COMPANY**



FIGURE A



FIGURE B

### INSERT INSTRUCTIONS

Determine which barrels in the array require

- » Inserts. Only those barrels with weights of 200, 400, 700 and 1,400 lbs. require Inserts. Barrels of 2,100 lbs. do not require inserts. Always install CrashGard Insert with the cone-shaped side face up.

Figure A: lean the barrel inward for

- » convenience. Hold the Insert, cone-shaped side face up, with both hands.

Figure B: CrashGard Insert is a square-sided

- » unit. Make sure that the configuration of the Insert matches the configuration of the barrel shelf upon which it rests. Slowly drop the Insert into position.

Once properly aligned, press-fit the Insert

- » into the barrel. There should be no rocking or sliding; the Insert should fit snugly.

The barrel is now ready to fill with sand.

### LIFTING INSTRUCTIONS

We designed CrashGard Sand Barrel

- » System for both safe and easy transport with CrashGard Hoist or a forklift.

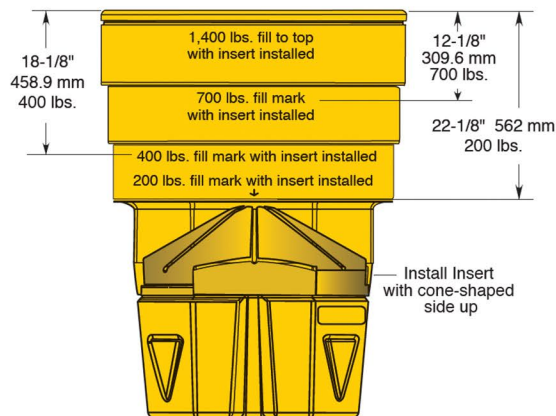

For 200, 400, 700 and 1,400 lbs. with Insert



For 2,100 lbs. without Insert

To determine sand fill levels from the inside of the barrel, use the measurements listed below. Measure from the TOP of the barrel to determine the appropriate fill level.

**Note: Specifications are approximate and subject to change. Some parts shown may be for illustration purposes only.**

### FORKLIFT INSTRUCTIONS:

To accommodate forklift trucks, we designed four flat sides, located just below the bottom round tier, at the 200 lb. fill level. We also designed that bottom tier to act as a "shelf" for the forklift blades.

- Caution: never stand or walk under a sand barrel during transport.
- Measure the distance between forklift blades, from inside to inside. That distance should not exceed 28".
- Figure C: align the blade with the flat sides of the barrel. If the barrel contains any significant weight, use the center of the blades for balance.
- Figure D: Many forklift blades become loose after years of use. To ensure the blades maintain consistent distance, we suggest using a chain binder, or similar type binding equipment.



FIGURE C



FIGURE D

# CrashGard® Temporary Attenuator

## Attenuator



**TRAFFIC SAFETY  
SUPPLY COMPANY**



### CRASHGARD HOIST

- » We designed and manufactured CrashGard Hoist for the safe, easy and efficient transport of CrashGard Sand Barrels. With CrashGard Hoist, loading or unloading a truck is at most a two-person operation, and often a one-person operation.
- » CrashGard Hoist operates in a scissor-like mode, to engage and disengage as necessary, and uses the CrashGard barrel itself to do so.
- » Made of welded steel.
- » Weighs 140 lbs.
- » Powder-coated paint helps deter corrosion



### CRASHGARD HOIST TRANSPORT INSTRUCTIONS

**Caution: never stand or walk under a sand barrel during transport.**

- » Figure A: using a boom, simply hook the Hoist's lifting ring. Raise the Hoist.
- » Figures B and C: align the Hoist over a CrashGard barrel, and slowly lower it. The lid of the barrel will open the Hoist.
- » Figures D and E: continue to lower the Hoist until it is fully open and rests upon the barrel top.
- » Figure F: raise the Hoist. The tension on the steel cables will cause the Hoist to clamp tightly, directly underneath the middle round tier.
- » Figure G: once engaged, continue to raise the Hoist, and carry it to its destination. Place the barrel where appropriate.

### DISENGAGE CRASHGARD HOIST INSTRUCTIONS

- » Lower the Hoist to full rest on the lid of the barrel. The Hoist will open.
- » While the Hoist is in the open position, simply slide it off either side of the barrel.
- » Once off, raise the Hoist clear of the barrel to pick up another.
- » Note: Some lifting devices made by other barrel manufacturers are adjustable by size. If using a device with settings to transport CrashGard, we recommend setting the device to "large".



**Note: Specifications are approximate and subject to change. Some parts shown may be for illustration purposes only.**

# CrashGard® Temporary Attenuator



**TRAFFIC SAFETY  
SUPPLY COMPANY**

	Design velocity 70 mph 19 barrels/arrary		Design velocity 45 mph 9 barrels/arrary
	Design velocity 65 mph 17 barrels/arrary		Design velocity 40 mph 8 barrels/arrary
	Design velocity 60 mph 14 barrels/arrary		Design velocity 35 mph 7 barrels/arrary
	Design velocity 55 mph 12 barrels/arrary		Design velocity 30 mph 7 barrels/arrary
	Design velocity 50 mph 10 barrels/arrary		Design velocity 25 mph 6 barrels/arrary

## MIXED ARRAY RECOMMENDATIONS

- » FHWA issued Acceptance Letter CC-97-A, an amendment to the original letter, CC-97. In CC-97-A, FHWA accepts the use of our CrashGard Sand Barrel in "mixed arrays".
- » A mixed array is defined as an array that contains barrels from different manufacturers. A mixed array usually evolves as portions of the original array are destroyed in crashes over time. Installers may replace the destroyed barrels with new ones from another manufacturer, thus creating the mixed array.

- » PSS advises and recommends that:
  - Installers should ALWAYS place CrashGard BEHIND shorter barrels.
  - Installers should NEVER place CrashGard IN FRONT OF shorter barrels.

- » PSS recommends installers follow the manufacturers' recommendation, design or plan that utilizes the highest number of barrels.
- » If placed incorrectly within an array, CrashGard may not perform as designed or intended.
- » Installers may place CrashGard in front of, next to, or behind other manufacturers' barrels, when those barrels are the same height as CrashGard.
- » CrashGard is completely interchangeable with other manufacturers' barrels of the same height.

**Note: Specifications are approximate and subject to change. Some parts shown may be for illustration purposes only.**

### Recommended Array Configurations

PSS recommends the above arrays for the designated speeds, as noted. To meet MASH requirements, please see new sand-fill measurements for 1,400 lb. barrels on page 2

### Conversion Chart

Speed		Weight	
MPH	Kilometers	Lbs.	Kilograms
25	40.2	200	90.7
30	48.3	400	181.4
35	56.3	700	317.5
40	64.4	1,400	635.0
45	72.4	2,100	952.5
50	80.5		
55	88.5		
60	96.6		
65	104.6		
70	112.6		

## PLACEMENT OF CRASHGARD SAND BARRELS IN MIXED ARRAYS

PLACE CrashGard behind shorter barrels

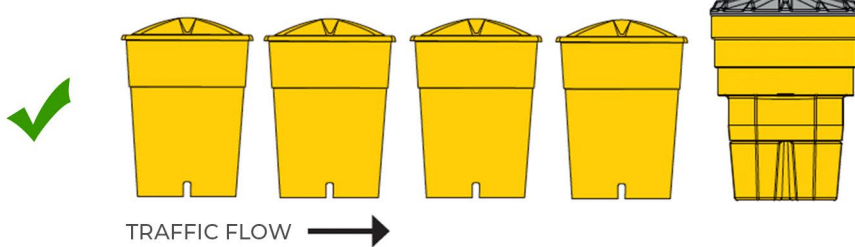

DO NOT place shorter barrels behind CrashGard

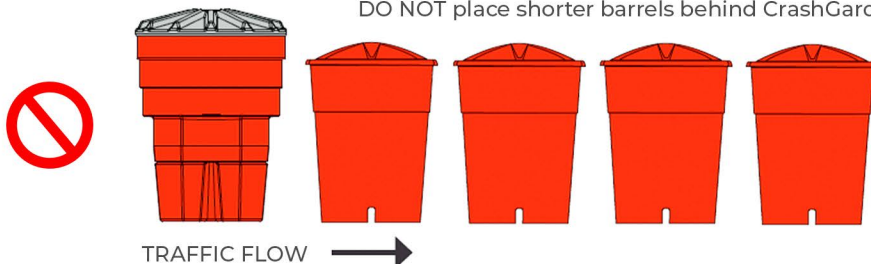



# CrashGard® Temporary Attenuator

## Attenuator



**TRAFFIC SAFETY  
SUPPLY COMPANY**

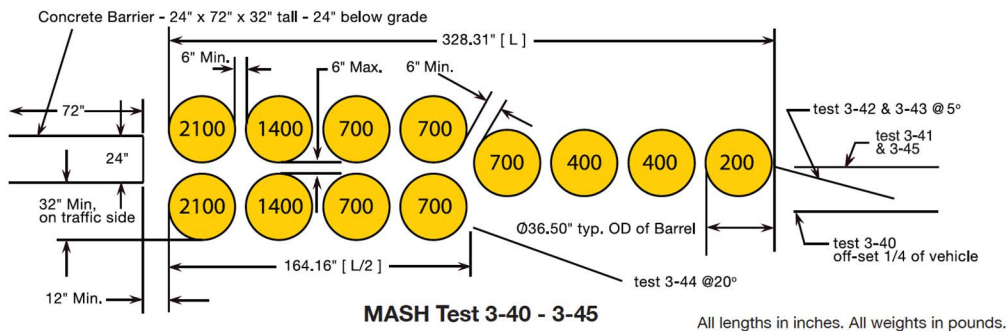

## CRASH TESTING

» MASH (Manual for Assessing Safety Hardware) Crash Test Guidelines supersede NCHRP-350 Test Guidelines. PSS crash-tested CrashGard Sand Barrel System » to Mash Test Level 3 Guidelines in Spring, 2018. CrashGard passed all MASH Tests. To meet MASH requirements, please see sand-fill measurements on page 2.

### 1. MASH Test 3-40:

Vehicle: Passenger Car  
Weight: 1,100 kg / 2,425 lbs.  
Impact Speed: 100 kph / 62 mph  
Impact Angle: 0° (Head-On)  
Offset 1/4 width of vehicle

### 2. MASH Test 3-41:

Vehicle: Pickup Truck  
Weight: 2,270 kg / 5,004 lbs.  
Impact Speed: 100 kph / 62 mph  
Impact Angle: 0° (Head-On)

### 3. MASH Test 3-42:

Vehicle: Passenger Car  
Weight: 1,100 kg / 2,425 lbs.  
Impact Speed: 100 kph / 62 mph  
Impact Angle: 5°

### 4. MASH Test 3-43:

Vehicle: Pickup Truck  
Weight: 2,270 kg / 5,004 lbs.  
Impact Speed: 100 kph / 62 mph  
Impact Angle: 5°

### 5. MASH Test 3-44:

Vehicle: Pickup Truck  
Weight: 2,270 kg / 5,004 lbs.  
Impact Speed: 100 kph / 62 mph  
Impact Angle: 20°

### 6. MASH Test 3-45:

Vehicle: Intermediate Vehicle  
Weight: 1,500 kg / 3,307 lbs.  
Impact Speed: 100 kph / 62 mph  
Impact Angle: 0°



**Note: Specifications are approximate and subject to change. Some parts shown may be for illustration purposes only.**